

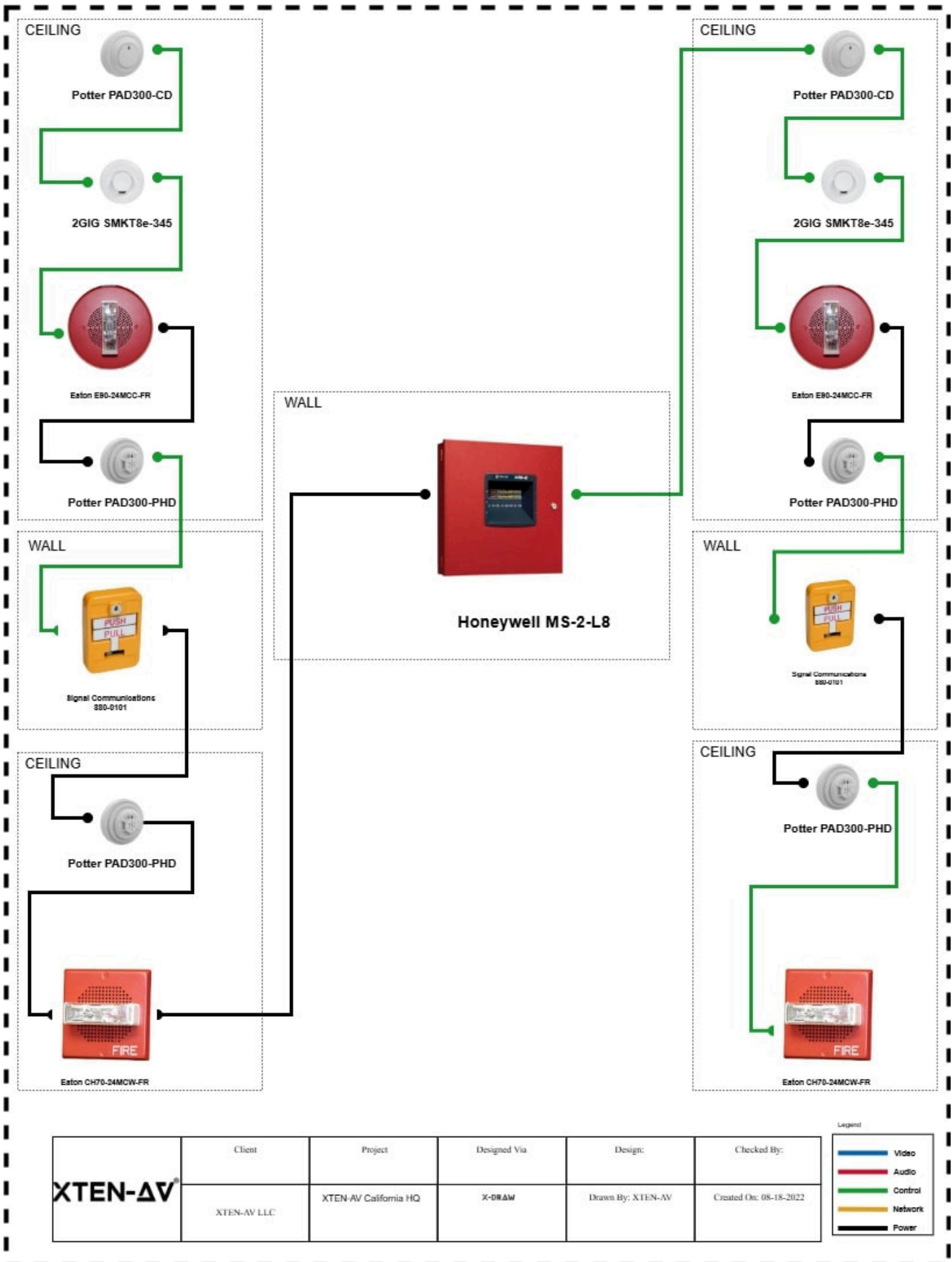

Addressable Fire Alarm Circuit Diagram Explained



Addressable fire alarm systems are widely used in modern buildings due to their precision, flexibility, and advanced monitoring capabilities. Unlike conventional systems, which trigger

alarms for an entire zone, addressable systems allow each device to communicate its status to the fire alarm control panel individually. Understanding how an addressable fire alarm circuit diagram works is essential for engineers, integrators, and safety professionals to ensure correct installation, compliance, and reliable operation. Fire Alarm System Design Software can simplify the creation and interpretation of these diagrams, providing clear, accurate, and code-compliant layouts.

XTEN-AV emphasizes that a detailed understanding of addressable fire alarm circuits is crucial for designing systems that protect occupants and property effectively. This guide explains the components, wiring, and logic behind addressable fire alarm circuits, along with best practices for creating and using circuit diagrams.

Understanding Addressable Fire Alarm Systems

An addressable fire alarm system assigns a unique address to each device, such as smoke detectors, heat detectors, manual call points, and notification appliances. This allows the control panel to identify the exact location of a triggered device.

Key advantages of addressable systems include:

- **Precise Location Identification:** The control panel can pinpoint the activated device, reducing response time and confusion during emergencies.
- **Flexible Zoning:** Zones can be easily reconfigured without changing physical wiring.
- **Advanced Diagnostics:** Addressable systems can monitor device status, detect faults, and provide maintenance alerts.
- **Integration Capability:** These systems can integrate with building management systems, elevators, sprinklers, and emergency lighting for coordinated responses.

Components of an Addressable Fire Alarm Circuit

A typical addressable fire alarm circuit consists of the following components:

- **Fire Alarm Control Panel:** The central hub that monitors all connected devices, processes signals, and initiates alarms or actions.
- **Addressable Detectors:** Smoke or heat detectors that report their status and have unique addresses recognized by the control panel.
- **Manual Call Points:** Devices that allow occupants to manually trigger the alarm system.
- **Notification Appliances:** Audible and visual alarms, such as sirens and strobes, activated based on control panel commands.
- **Loop Wiring:** A single pair of wires that connects all devices in a loop configuration, allowing two-way communication with the control panel.
- **Power Supply and Backup:** Ensures uninterrupted operation during power failures, often including batteries for emergency operation.

How Addressable Circuits Work

Addressable circuits use loop wiring to connect multiple devices in series or parallel, allowing two-way communication. Each device constantly communicates its status to the control panel, reporting normal operation, alarm conditions, or faults.

- **Normal Operation:** Devices periodically send a signal to confirm they are functioning correctly.
- **Alarm Condition:** When a device detects smoke, heat, or manual activation, it sends an alarm signal along with its unique address to the control panel.
- **Fault Condition:** If a device or wiring section fails, the control panel identifies the problem and notifies maintenance personnel.

This communication enables centralized monitoring and precise management of fire safety across the building.

Reading an Addressable Fire Alarm Circuit Diagram

An addressable fire alarm circuit diagram illustrates how devices are connected, powered, and monitored. Key elements include:

- **Loop Configuration:** The diagram shows the start and end points of the loop, with all devices connected along the loop.
- **Device Addresses:** Each device is labeled with its unique address for identification and programming.
- **Power Connections:** Indicate how the devices receive power from the control panel or auxiliary power supply.
- **Notification Devices:** Show the wiring and control connections for alarms, sirens, or strobes.
- **Control Panel Inputs and Outputs:** Include relay outputs for integration with other building systems, such as emergency lighting or HVAC shutdown.

Fire Alarm System Design Software can generate addressable circuit diagrams automatically based on device selection and building layout. This ensures accuracy, consistent labeling, and adherence to codes.

Design Considerations for Addressable Circuits

When designing an addressable fire alarm circuit, several factors should be considered:

- **Device Placement:** Ensure proper spacing and coverage according to code requirements. Avoid placing detectors near vents, fans, or high airflow areas that may interfere with detection.
- **Loop Loading:** Each loop has a maximum number of devices it can support. Exceeding this limit can cause communication failures.

- **Wire Type and Length:** Use wires compatible with the control panel specifications, and account for voltage drop and signal integrity over long distances.
- **Power Requirements:** Ensure sufficient power is supplied for all devices, including notification appliances. Include backup batteries for uninterrupted operation.
- **Redundancy and Fault Tolerance:** Some systems allow multiple loops or backup paths to maintain communication if a wiring section is damaged.

Creating an Addressable Circuit Diagram with Software

Fire Alarm System Design Software offers several benefits for creating addressable circuit diagrams:

- **Automated Device Placement:** Software can suggest optimal device positions based on room size and occupancy.
- **Loop Configuration Assistance:** Automatically generates loop wiring and calculates maximum device loads.
- **Compliance Checks:** Ensures that placement, spacing, and wiring adhere to NFPA, IS, or local standards.
- **Documentation Generation:** Produces clear diagrams, device lists, and reports that can be used for installation and inspection.
- **Error Detection:** Highlights potential issues such as overlapping devices, incorrect addresses, or power limitations.

Using software reduces human error, saves time, and produces professional-grade diagrams ready for project approvals and installation teams.

Best Practices for Addressable Fire Alarm Circuits

To ensure reliability and compliance, follow these best practices:

- Involve all stakeholders, including architects and MEP engineers, early in the design process.
- Plan loop layouts carefully to avoid unnecessary crossings or long wiring runs.
- Assign addresses logically to simplify programming and troubleshooting.
- Include maintenance and test points to facilitate regular system checks.
- Keep detailed documentation for future maintenance and system expansion.

Conclusion

Addressable fire alarm systems offer precise detection, advanced diagnostics, and seamless integration with other building safety systems. Understanding and creating accurate addressable fire alarm circuit diagrams is essential for ensuring reliable operation and code compliance.

XTEN-AV highlights the value of Fire Alarm System Design Software in this process, as it streamlines diagram creation, automates loop calculations, and enhances collaboration among project teams. By following proper design practices, engineers and integrators can implement addressable fire alarm systems that maximize safety, efficiency, and long-term reliability.

Read more: <https://trendverity.com/fire-alarm-circuit-design-for-beginners-how-it-works/>